



Hi3536 H.265 Decoder Processor

## **Brief Data Sheet**

**Issue**            **03**

**Date**             **2015-04-19**

**Copyright © HiSilicon Technologies Co., Ltd. 2014. All rights reserved.**

No part of this document may be reproduced or transmitted in any form or by any means without prior written consent of HiSilicon Technologies Co., Ltd.

## **Trademarks and Permissions**



**HISILICON**, and other HiSilicon icons are trademarks of HiSilicon Technologies Co., Ltd.

All other trademarks and trade names mentioned in this document are the property of their respective holders.

## **Notice**

The purchased products, services and features are stipulated by the contract made between HiSilicon and the customer. All or part of the products, services and features described in this document may not be within the purchase scope or the usage scope. Unless otherwise specified in the contract, all statements, information, and recommendations in this document are provided "AS IS" without warranties, guarantees or representations of any kind, either express or implied.

The information in this document is subject to change without notice. Every effort has been made in the preparation of this document to ensure accuracy of the contents, but all statements, information, and recommendations in this document do not constitute a warranty of any kind, express or implied.

## **HiSilicon Technologies Co., Ltd.**

Address: Huawei Industrial Base  
Bantian, Longgang  
Shenzhen 518129  
People's Republic of China

Website: <http://www.hisilicon.com>

Email: [support@hisilicon.com](mailto:support@hisilicon.com)



# Hi3536 H.265 Decoder Processor

## Key Specifications

### Processor Core

- ARM Cortex A17 quad-core@maximum 1.4 GHz
  - 32 KB L1 I-cache, 32 KB L1 D-cache
  - 1 MB L2 cache
  - Main control processor for running peripheral drivers and applications
- ARM Cortex A7 single-core@maximum 900 MHz
  - 32 KB L1 I-cache, 32 KB L1 D-cache
  - 128 KB L2 cache
  - Video-related module control

### Video Decoding Standards

- H.265 Main Profile L5.1
- H.264 Baseline/Main/High profile L5.0
- MPEG4 SP L0–3/ASP L0–5
- MJPEG/JPEG baseline

### Video Encoding Standards

- H.264 Baseline/Main/High profile L5.1
- MJPEG/JPEG baseline

### Video Encoding/Decoding

- H.265/H.264&JPEG encoding and decoding of multiple streams:
  - 4-channel 4K x 2K (3840 x 2160)@30 fps H.265/H.264 decoding+2x1080p@30 fps H.264 encoding+4-channel 4K x 2K@2 fps JPEG encoding
  - 16x1080p@30 fps H.265/H.264 decoding+2x1080p@30 fps H.264 encoding+16x1080p@2 fps JPEG encoding
  - 9x1080p@30 fps H.265/H.264 decoding+4K x 2K@30 fps H.264 encoding+9x1080p@2 fps JPEG encoding
  - 32x720p@30 fps H.265/H.264 decoding+4x720p@30 fps H.264 encoding+32x720p@2 fps JPEG encoding
  - 64xD1@30 fps H.265/H.264 decoding+8xD1@30 fps H.264 encoding+64xD1@2 fps JPEG encoding
  - 9x720p@30 fps JPEG decoding
- CBR or VBR, ranging from 16 kbit/s to 40 Mbit/s
- Encoding frame rate ranging from 1 fps to 60 fps
- ROI encoding
- Color-to-gray encoding

### GPU

- Integrated Mali-T720 GPU
- OpenGL ES3.1/2.0/1.1
- OpenCL 1.2/1.1/1.0
- Up to 63 MTris/s triangle filling rate
- Double-precision FP64 and anti-aliasing

### Intelligent Video Analysis

- Integrated IVE 2.0, supporting various intelligent analysis applications:
  - Motion detection
  - Video diagnosis
  - Perimeter protection

### Video and Graphic Processing

- 3D denoising, deinterlacing, edge smoothing, dynamic contrast enhancement and sharpening
- Anti-flicker for output videos and graphics
- 1/8x to 16x video scaling
- 1/2x to 2x graphic scaling
- Four cover regions
- OSD overlaying of eight regions

### Video Interfaces

- VI interfaces
  - One BT.1120 HD input port
  - One video input channel for dual-chip cascading
  - SDR and DDR modes
  - Maximum input of 1080p@60 fps in SDR mode
  - Maximum input of 3840 x 2160@30 fps in DDR mode
- VO interfaces
  - One HDMI 2.0 ultra-HD output interface, support output up to 3840 x 2160@60 fps
  - One VGA HD output interface, support output up to 2560 x 1600@60 fps
  - One BT.1120 HD output port, supporting the maximum output of 1080p@60 fps in SDR mode or 3840 x 2160@30 fps in DDR mode
  - Two independent HD output channels (DHD0 and DHD1), output from any HD interface (HDMI, VGA, and BT.1120)
  - 64-picture output for DHD0, maximum 3840 x 2160@60 fps output
  - 32-picture output for DHD1, maximum 1080p@60 fps output
  - One CVBS SD output interface
  - Three full-screen GUI graphics layers in RGB1555 or RGB8888 format, used by two HD channels and one SD channel
  - Two hardware cursor layers in RGB1555, RGB4444 or RGB8888 format, with the maximum resolution of 256 x 256

### Audio Interfaces

- One integrated audio CODEC
- Three unidirectional I<sup>2</sup>S/PCM interfaces
  - One input, supporting 16 multiplexed inputs
  - Two outputs
- 16-bit audio input and output

### Ethernet Ports

- Two gigabit Ethernet ports
  - RGMII, RMII, and MII modes
  - 10/100 Mbit/s full-duplex or half-duplex
  - 1000 Mbit/s full-duplex
  - TOE for reducing the CPU usage

### Security Engine

- AES, DES, 3DES algorithms



# Hi3536 H.265 Decoder Processor

- HASH abstract algorithm

## RAID Acceleration Engine

- XOR acceleration
- Up to nine data sources for XOR
- DMA, up to 16 MB data block
- Memory initialization (configurable initial value)
- Descriptor linked list

## Peripheral Interfaces

- Two SATA 3.0 interfaces
  - PM
  - eSATA
- One PCIe 2.0/SATA 3.0 interfaces
  - Two PCIe interfaces, one PCIe interface+one SATA interface, or two SATA interfaces
  - RC and EP supported as the PCIe 2.0 interface
  - eSATA supported as the SATA 3.0 interface
- Two USB 2.0 host ports, supporting hub
- One USB 3.0 host port, supporting hub
- Two SDIO interfaces
  - SD 2.0, SDIO 2.0, MMC 4.4.1, and SDXC (only 3.3 V mode) cards supported for SDIO0 and SDIO1
  - Only eMMC 4.5 card supported for SDIO1
  - Multiplexing between SDIO0 and BT.1120 output pins
  - Multiplexing between SDIO1 and NAND flash interface pins
- Four UART interfaces, two of which supporting four wires
- One IR interface
- One I<sup>2</sup>C interface
- Multiple GPIO interfaces
- One low-speed ADC interface

## Memory Interfaces

- Two 32-bit DDR3/4 SDRAM interfaces
  - Maximum frequency of 933 MHz (1.866 Gbit/s)
  - Dual channels
  - ODT
  - Maximum capacity of 3 GB
- SPI NOR/NAND flash interface
  - 1-/2-/4-bit SPI NOR/NAND flash
  - Two CSs
  - Maximum 32 MB for each CS (for only the NOR flash)

- Maximum 8 GB for each CS (for only the NAND flash)
- 2 KB/4 KB page size (for only the NAND flash)
- 8-bit/1 KB and 24-bit/1 KB ECC (for only the NAND flash)

- NAND flash interface
  - 8-bit NAND flash
  - Two CSs
  - SLC or MLC
  - 8-/24-/40-/64-bit ECC based on the 1 KB data block
- Embedded 64 KB BOOTROM and 88 KB SRAM

## RTC with an Independent Power Supply

- Independent battery for supplying power to the RTC

## Boot Modes

- Booting from the BOOTROM
- Booting from the SPI NOR flash
- Booting from the SPI NAND flash
- Booting from the NAND flash
- Booting from the eMMC
- Booting the slave chip over the PCIe interface

## SDK

- Linux 3.10-based SDK
- Audio encoding and decoding libraries complying with various protocols
- High-performance H.265/H.264 PC decoding library

## Physical Specifications

- Power consumption
  - Typical power consumption of 4.3 W
  - Multi-level power-saving control
- Operating voltages
  - 0.9 V core voltage
  - 1.0 V CPU voltage (or decreased to 0.9 V)
  - 3.3 V I/O voltage
  - 1.5/1.2 V DDR3/4 SDRAM interface voltage
- Package
  - RoHS, EDHS-PBGA
  - Ball pitch of 0.8 mm (0.02 in.)
  - Body size of 27 mm x 27 mm (1.06 in. x 1.06 in.)
- Operating temperature ranging from 0°C (32°F) to 70°C (158°F)

# Hi3536 H.265 Decoder Processor

## Functional Block Diagram

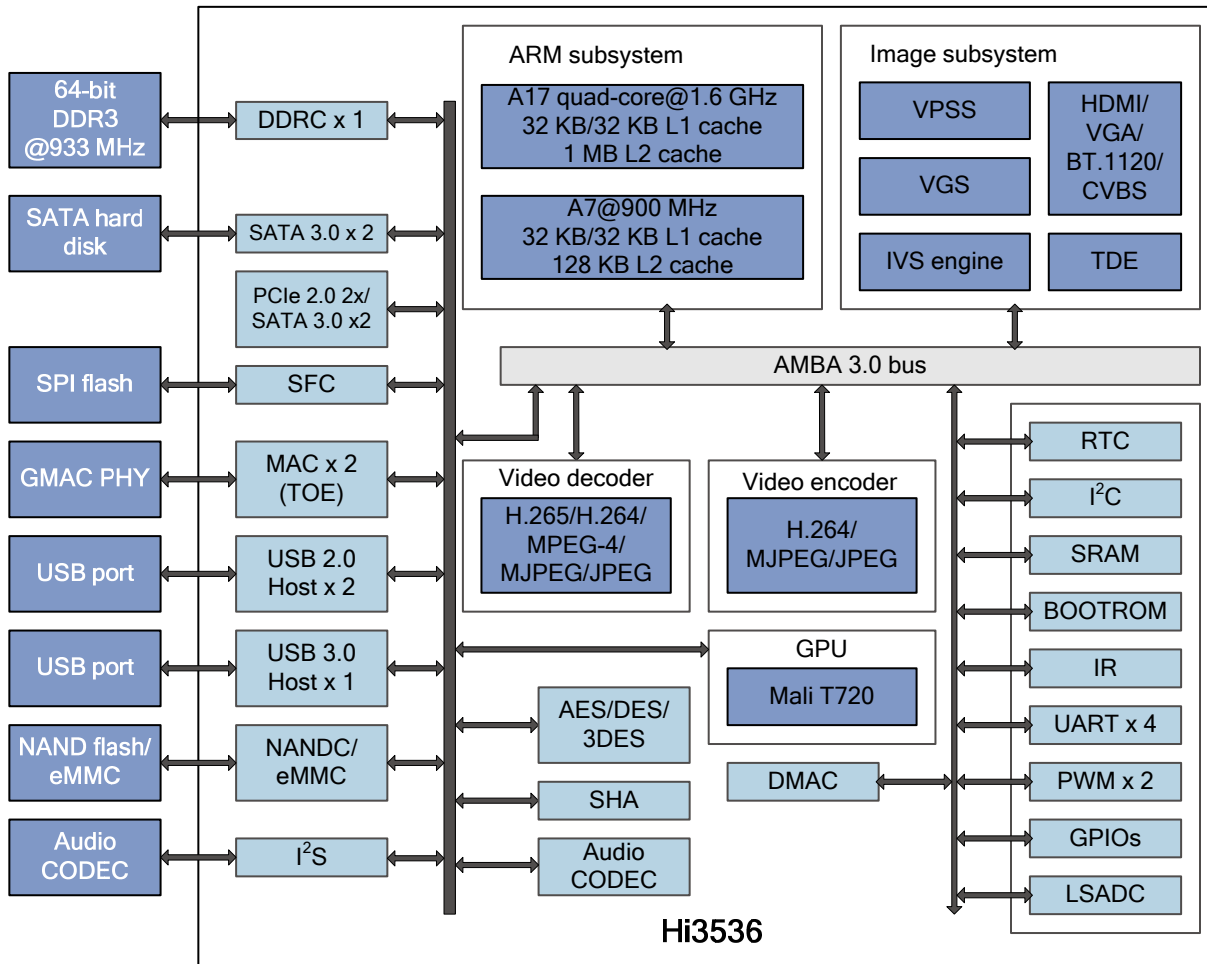

The Hi3536 is a professional high-end SoC targeted for the multi-channel HD or D1 NVR. The Hi3536 provides a high-performance A17 processor, a video decoding engine (a maximum of 16x1080p decoding complying with various protocols), a high-performance video/graphics processing engine (various complicated graphics processing algorithms), and dual-channel HD outputs. These features enable the Hi3536 to provide high-quality images. In addition, the Hi3536 integrates various peripheral interfaces to meet differentiated customer requirements for functionality, features, and image quality, while reducing the eBOM cost.

## NVRs (Each with a Hi3536)

### 16x1080p NVR

- 32x1080p@10 Mbit/s streams
- 16x1080p real-time decoding (16-channel polling previewing)
- 2x1080p real-time encoding
- 1080p@32 fps JPEG snapshot
- HDMI 4K x 2K@30 fps 16-picture ultra-HD output

### 32x720p NVR

- 64x720p@5 Mbit/s streams
- 32x720p real-time decoding (32-channel polling previewing)
- 4x720p real-time encoding



# Hi3536 H.265 Decoder Processor

- 720p@64 fps JPEG snapshot
- HDMI+VGA 1080p@60 fps HD dual 16-picture output

## 64xD1 NVR

- 128xD1@2.5 Mbit/s streams
- 64xD1 real-time decoding (64-channel real-time previewing)
- 8xD1 real-time encoding
- D1@128 fps JPEG snapshot
- HDMI 4K x 2K@30 fps 64-picture ultra-HD output

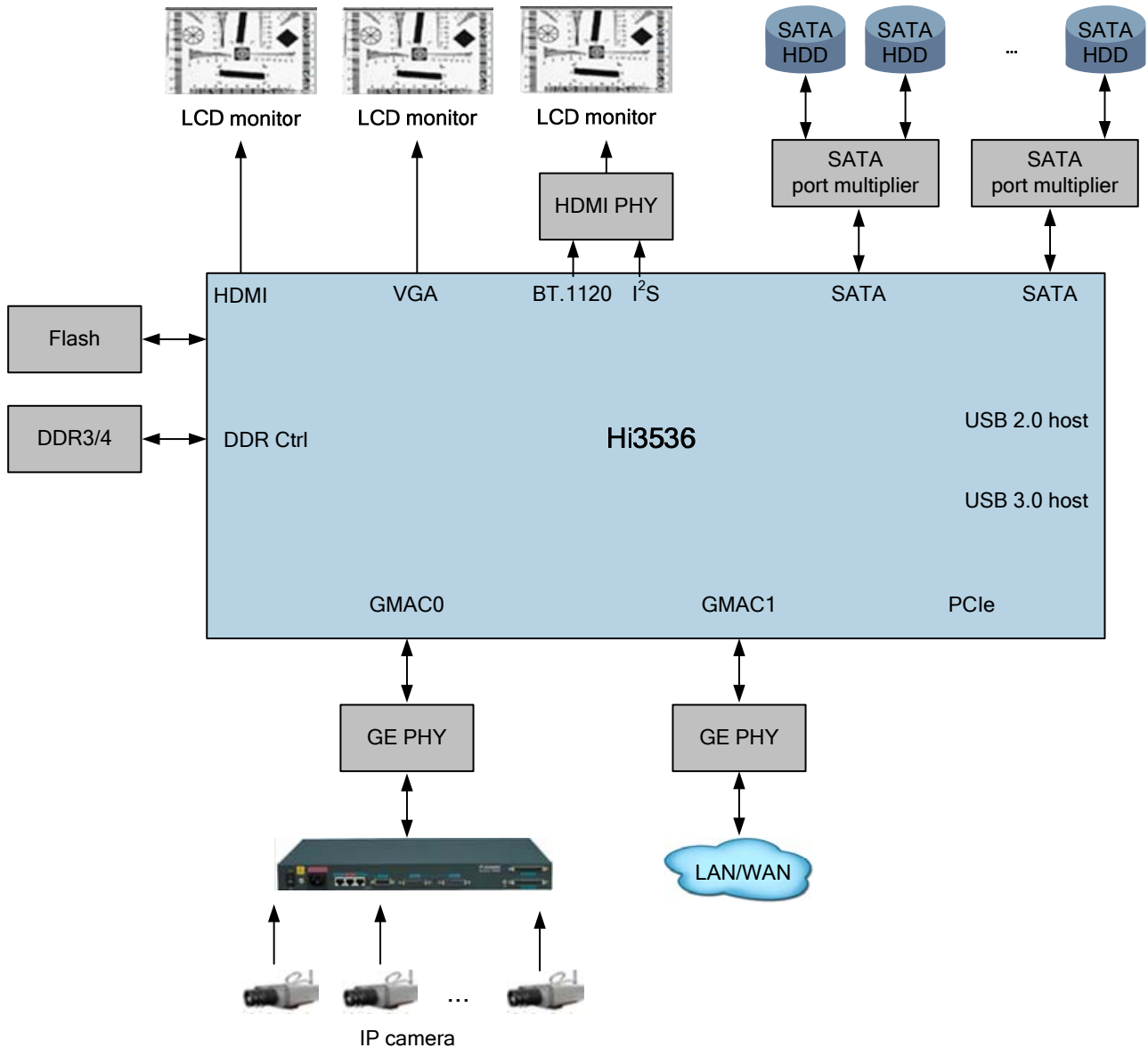



# Hi3536 H.265 Decoder Processor

## Acronyms and Abbreviations

3DES	triple data encryption standard
AES	advanced encryption standard
CBR	constant bit rate
CS	chip select
CVBS	composite video broadcast signal
DDR	double-data rate
DES	data encryption standard
DMA	direct memory access
ECC	error correcting code
EP	endpoint
eSATA	external serial advanced technology attachment
GPIO	general-purpose input/output
GUI	graphical user interface
HD	high-definition
HDMI	high-definition multimedia interface
I <sup>2</sup> C	inter-integrated circuit
I <sup>2</sup> S	inter-IC sound
IR	infrared
IVE	intelligent video engine
MII	media independent interface
MLC	multi-level cell
NVR	network video recorder
ODT	on-die termination
OSD	on-screen display
PBGA	plastic ball grid array
PCIe	peripheral component interconnect express
PM	port multiplexer
RAID	redundant array of independent disks
RC	root complex
RGMII	reduced gigabit media independent interface
RMII	reduced media independent interface
RoHS	restriction of the use of certain hazardous substances
ROI	region of interest
RTC	real-time clock
SATA	serial advanced technology attachment
SD	standard-definition
SDR	single data rate
SDK	software development kit
SDRAM	synchronous dynamic random access memory
SHA	secure hash algorithm
SLC	single-level cell
SMMU	system memory management unit
SoC	system-on-chip
SP	simple profile
SPI	serial peripheral interface
SRAM	static random access memory
TOE	TCP/IP offload engine
UART	universal asynchronous receiver transmitter
VBR	variable bit rate
VGA	video graphics array
VO	video output